

### Application

The AV-611 linkage is designed to link the Schneider Electric SmartX Actuators Mx41-6xx3 (non-spring return) and Mx40-704x (spring return) shown in Table-1 to 1/2" through 2" VB-7xxx and 1/2" through 1-1/4" discontinued VB-9xxx 2-way and 3-way globe valves.

**Table-1 Actuators**

Actuator	Descriptions
MF41-6043	Floating 35 lb-in non-spring return
MS41-6043	Proportional 35 lb-in non-spring return
MF41-6083	Floating 70 lb-in non-spring return
MS41-6083	Proportional 70 lb-in non-spring return
MF41-6153	Floating 133 lb-in non-spring return
MS41-6153	Proportional 133 lb-in non-spring return
MA40-704x	Two-position 35 lb-in spring return
MF40-7043	Floating 35 lb-in spring return
MS40-7043	Proportional 35 lb-in spring return

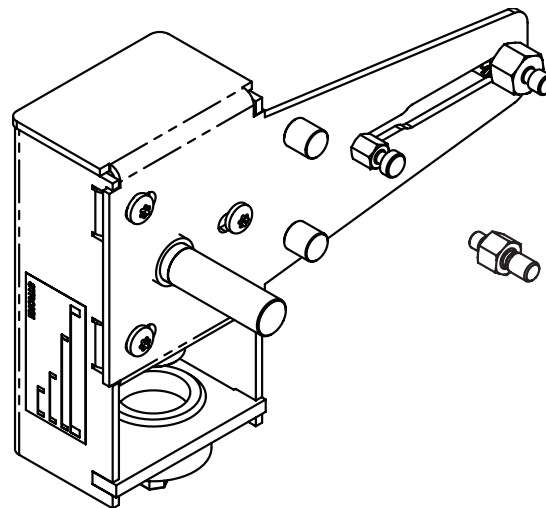

### Applicable Literature

- Mx41-6043, Mx41-6083 Series non-spring return actuator General Instructions, F-27213.
- Mx41-6153 Series Non-spring return actuator General Instructions, F-27215.
- MA40-704x, MA4x-707x, MA4x-715x Series spring return actuator General Instructions, F-26642.
- MF40-7043, MF4x-707x, MF4x-715x Series spring return actuator General Instructions.
- Vx-7000 & Vx-9000 Series Mx41-6xxx & Mx4x-7xxx Series Linked Globe Valve Assemblies Selection Guide, F-26752.
- VB-7211 Series Valve Body General Instructions, F-24380
- VB-7212 Series Valve Body General Instructions, F-24381.
- VB-7213 Series Valve Body General Instructions, F-26075.
- VB-7214 Series Valve Body General Instructions, F-25675.
- VB-7215 Series Valve Body General Instructions, F-26077.
- VB-7221 Series Valve Body General Instructions, F-24384.
- VB-7222 Series Valve Body General Instructions, F-24385.
- VB-7223 Series Valve Body General Instructions, F-26073.
- VB-7224 Series Valve Body General Instructions, F-25387.
- VB-7225 Series Valve Body General Instructions, F-26079.
- VB-7312 Series Valve Body General Instructions, F-24392.
- VB-7313 Series Valve Body General Instructions, F-26074.
- VB-7314 Series Valve Body General Instructions, F-24394.
- VB-7315 Series Valve Body General Instructions, F-26078
- VB-7323 Series Valve Body General Instructions, F-26076.
- VB-7332 Series Valve Body General Instructions, F-24396.

## Inspection

Inspect the package for damage. If damaged, notify the appropriate carrier immediately. If undamaged, open the package and inspect the device for obvious damage. Return any damaged products.

## Requirements

- Training: Installer must be a qualified, experienced technician.
- Tools (not provided):
  - Appropriate wrenches for stem extensions, packing nuts, and bracket nuts
  - 10 mm socket wrench (for shaft clamp nuts on Mx41-6153 and Mx40-704x)
  - Torque wrench, range to include 60 to 120 lb.-in. (6.8 to 14 N-m)
  - Pipe wrenches, two
  - TOOL-37, 1-5/8 inch open-end wrench for valve mounting nut
  - 5/16" open-end wrench for jam nuts (or TOOL-20-1 or equivalent)
  - Vise grip or pliers
  - Appropriate power supply (see the applicable actuator General Instructions sheet for power requirements)



---

### Warning:

- Disconnect the power supply (line power) before installation to prevent equipment damage.
  - Make all connections in accordance with the job wiring diagram and in accordance with national and local electrical codes. *Use copper conductors only.*
- 

## Mounting

Allow at least 5" (127 mm) above the actuator/linkage assembly for removal and reattachment of the actuator to the installed valve.

## Assembling Actuator and Linkage to Valve Body

### Process Overview

This assembly procedure consists of two sections:

- **Section A. Assembling Linkage to Valve — All Valve Types and Actuator Models**

For all actuator models and valve types (2-way and 3-way), follow the instructions in this section to assemble the linkage to the valve.

- **Section B. Actuator Mounting and Setup**

In this section, choose the subsection that is appropriate for the specific actuator type and valve type, to mount the actuator and adjust the linkage:

- **B1. Mx41-6043 and Mx41-6083 Non-spring Return Actuators with Manual Override — 2-Way (Stem Up Open, Stem Up Closed) and 3-Way Valves**

These instructions apply to actuators with manual override, to be mounted onto 2-way valves (stem up closed and stem up open) and 3-way valves

- **B2. Mx41-6153 Non-Spring Return Actuators with Manual Override — 2-Way Valves (Stem Up Closed and Stem Up Open) and 3-Way Valves**

These instructions apply to actuators with manual override, to be mounted onto 2-way valves (stem up closed and stem up open) and 3-way valves.

- **B3. Mx40-704x Spring Return Actuators without Manual Override — 2-Way Valves (Stem Up Closed and Stem Up Open)**

These instructions apply to spring return actuators, to be mounted onto 2-way valves (stem up closed and stem up open).

- **B4. Mx40-704x Spring Return Actuators without Manual Override — 3-Way Valves**

These instructions apply to spring return actuators, to be mounted onto 3-way valves.

Refer to Table-2, on the next page, to determine the assembly path for the specific actuator and valve.

**Table-2 Assembly Process for Mounting Actuator and Linkage to Valve Body.**

Actuator Type	Valve Type	Section A	Section B			
			Subsection B1	Subsection B2	Subsection B3	Subsection B4
Non-spring Return Actuators with Manual Override: Mx41-6043 Mx41-6083	2-Way Stem-Up Open	X	X			
	2-Way Stem-Up Closed	X	X			
	3-Way	X	X			
Non-spring Return Actuators with Manual Override: <b>MX41-6153</b>	2-Way Stem-Up Open	X		X		
	2-Way Stem-Up Closed	X		X		
	3-Way	X		X		
Spring Return Actuators without Manual Override: <b>MX40-704X</b>	2-Way Stem-Up Open	X			X	
	2-Way Stem-Up Closed	X			X	
	3-Way <sup>a</sup>	X				X

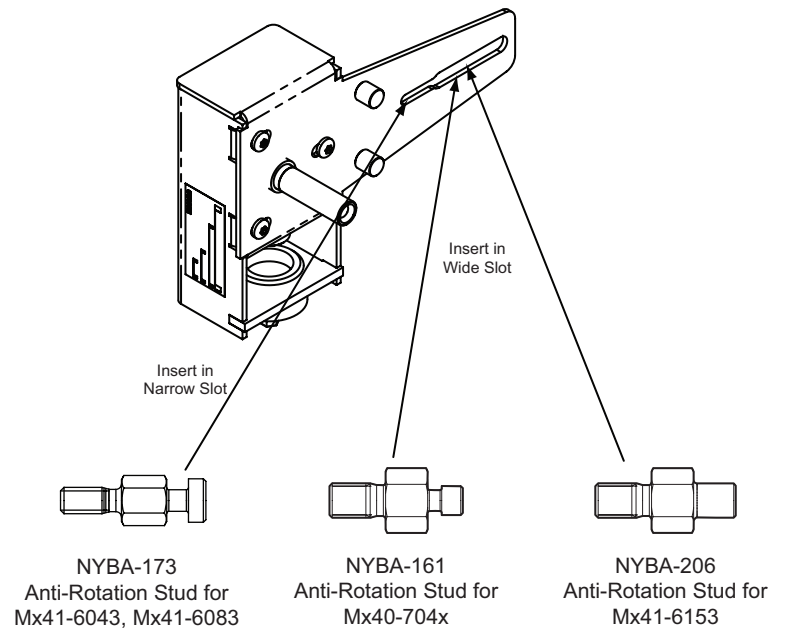

Figure-1 Anti-Rotation Studs.

### Section A. Assembling Linkage to Valve — All Valve Types and Actuator Models

1. If necessary, remove unused anti-rotation studs from linkage (see Figure-1 on page 3)
2. Assemble the linkage to the valve, according to Figure-2.

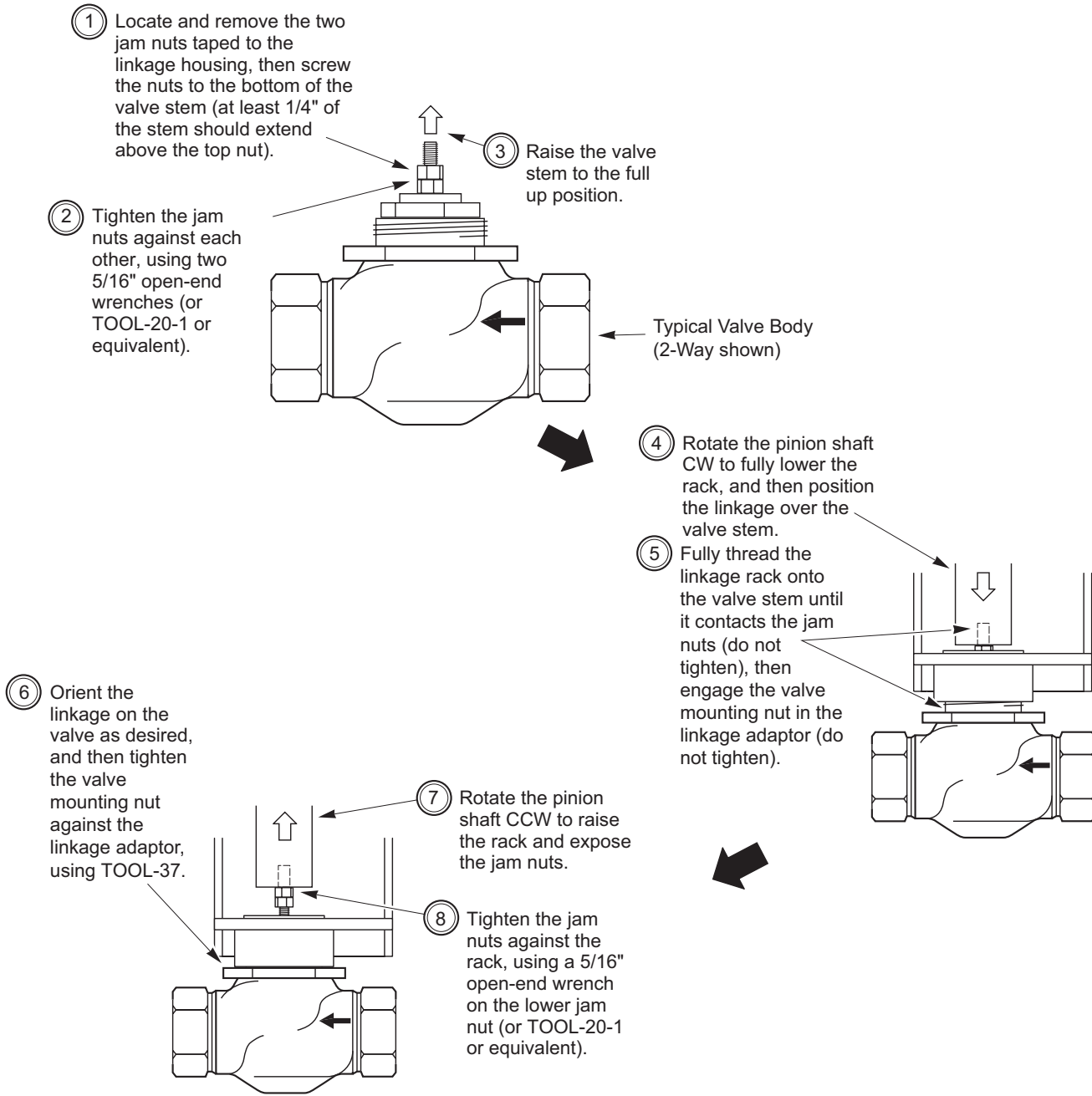

Figure-2 Assembling Linkage to Valve.

3. Continue the assembly process according to the following section, "Section B. Actuator Mounting and Setup."

## Section B. Actuator Mounting and Setup

To mount the actuator and set up the assembly, refer to the subsection that applies to the specific actuator type and valve type.

### B1. Mx41-6043 and Mx41-6083 Non-spring Return Actuators with Manual Override — 2-Way (Stem Up Open, Stem Up Closed) and 3-Way Valves

- a. Confirm that the NYBA-173 anti-rotation stud is installed in the narrow slot of the linkage (refer to Figure-1 on page 3). Install the actuator onto the linkage and valve and set up the assembly as shown in Figure-3.

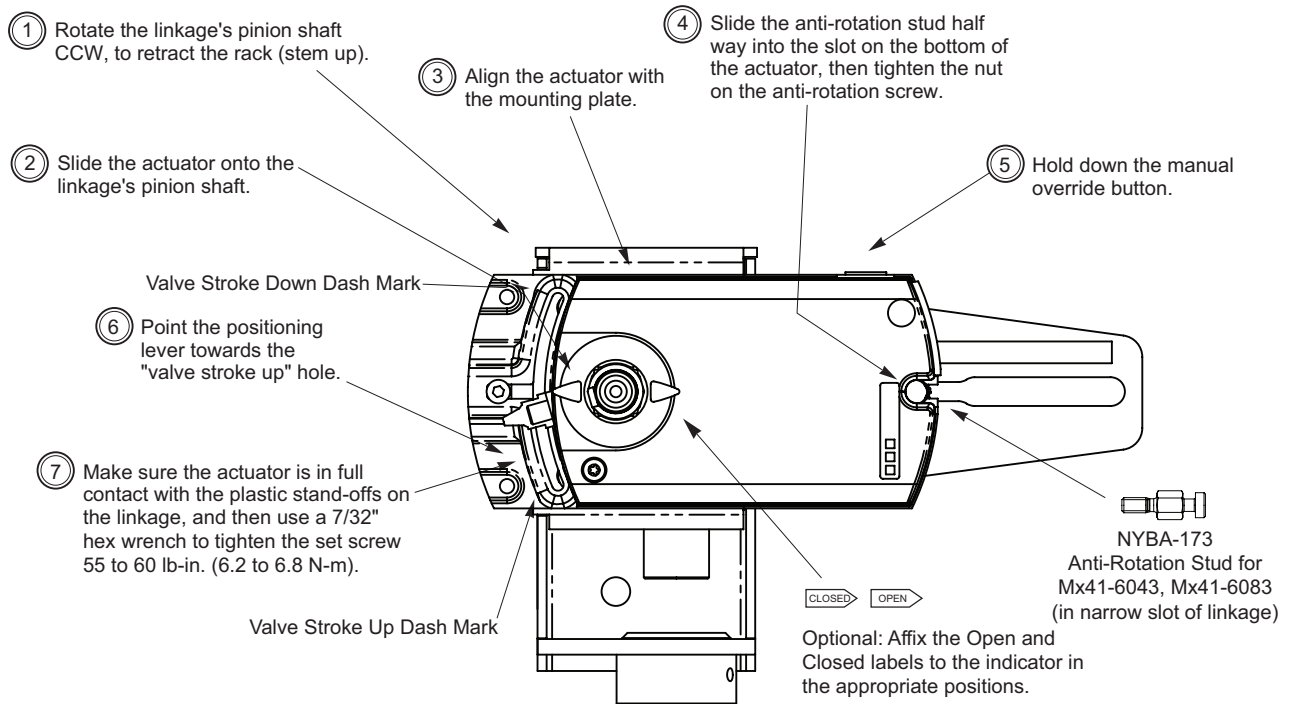

Figure-3 Mounting Mx41-6043 and Mx41-6083 Actuators and Setting Up Actuator/Linkage/Valve Assembly

- b. Apply power to the actuator and check the system's operation for heating or cooling output in response to the control signal.
- c. Refer to the appropriate actuator General Instructions sheet for actuator wiring and application information. For valve body installation and application information, refer to the appropriate valve body General Instructions sheet. Refer to "Applicable Literature" on page 1.

## B2. Mx41-6153 Non-Spring Return Actuators with Manual Override — 2-Way Valves (Stem Up Closed and Stem Up Open) and 3-Way Valves

- a. Confirm that the NYBA-206 anti-rotation stud is installed in the wide slot of the linkage (refer to Figure-1 on page 3). Install the actuator onto the linkage and valve, and set up the assembly, according to Figure-4 below.

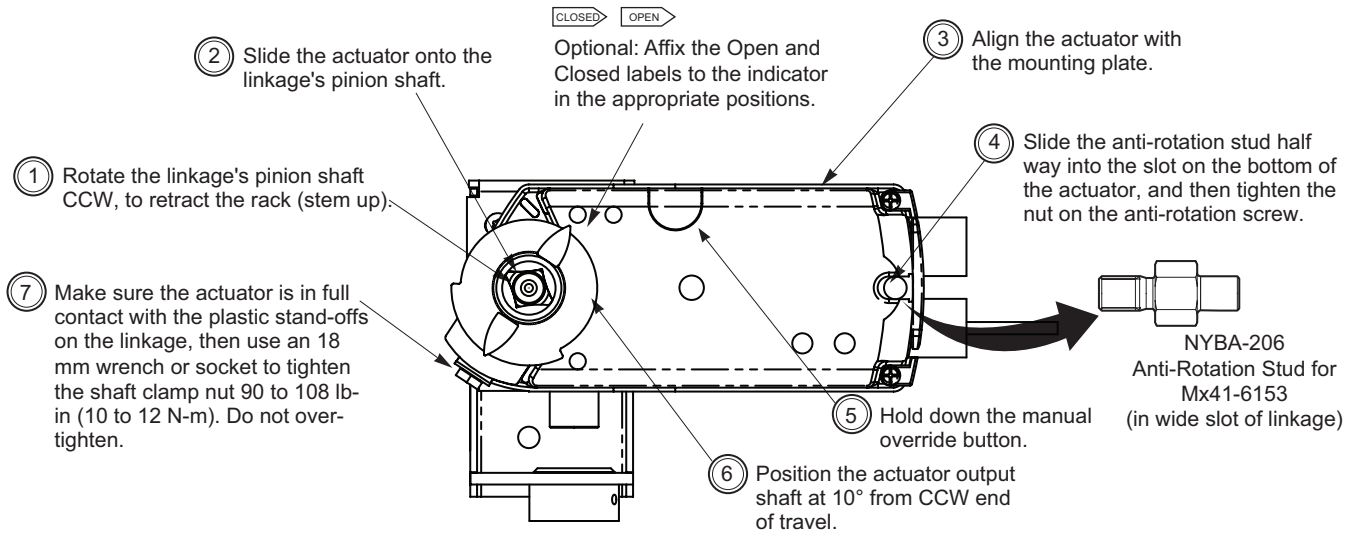

Figure-4 Mounting Mx41-6153 and Setting up Actuator/Linkage/Valve Assembly.

- b. Apply power to the actuator and check the system's operation for heating or cooling output, in response to the control signal.
- c. Refer to the appropriate actuator General Instructions sheet for actuator wiring and application information. For valve body installation and application information, refer to the appropriate valve body General Instructions sheet. Refer to "Applicable Literature" on page 1.

### B3. Mx40-704x Spring Return Actuators without Manual Override — 2-Way Valves (Stem Up Closed and Stem Up Open)

- a. Confirm that the NYBA-161 anti-rotation stud is installed in the wide slot of the linkage (refer to Figure-1 on page 3). Install the actuator onto the linkage and 2-way valve, and set up the assembly, according to Figure-5 below.

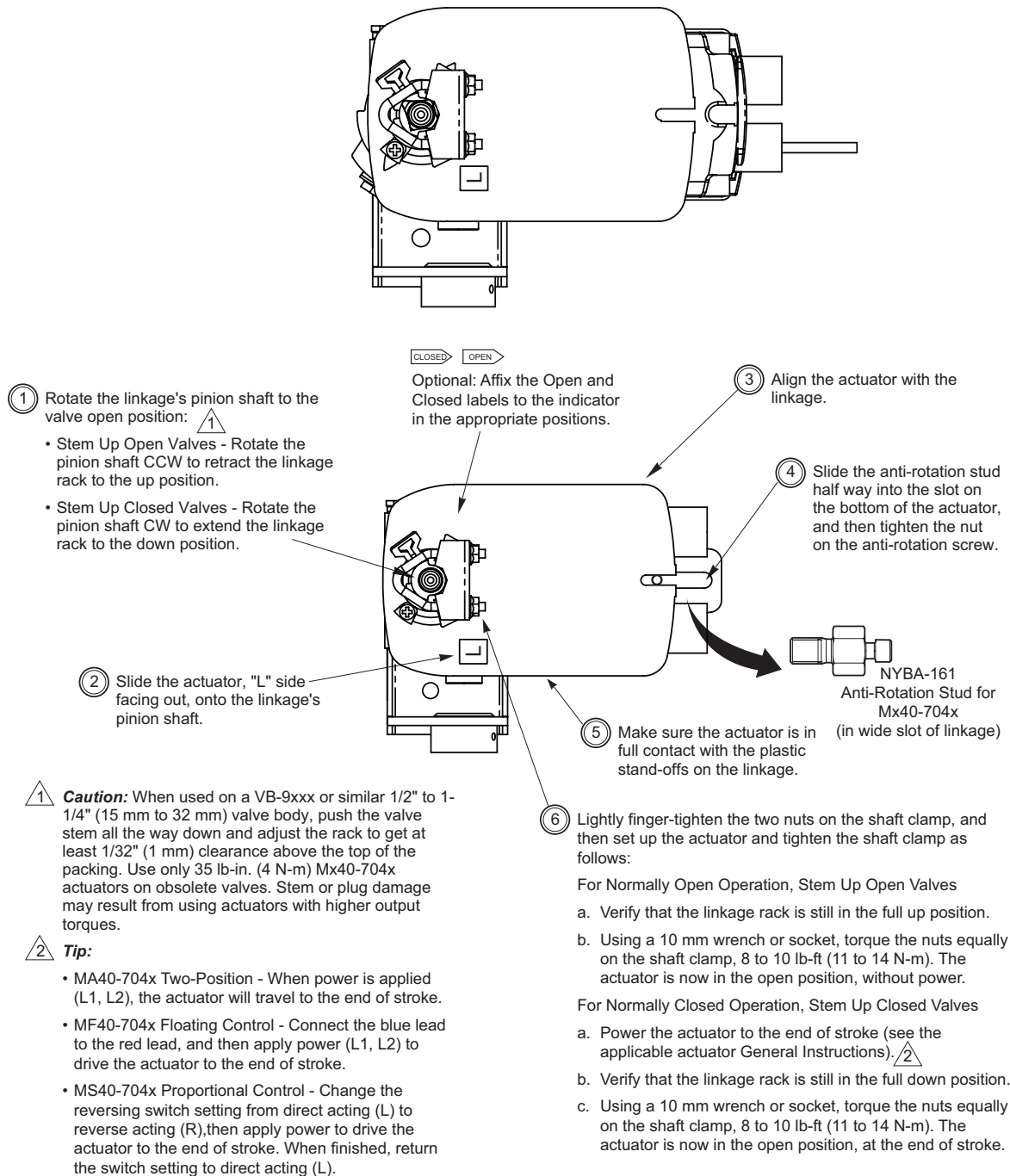

Figure-5 Mounting Mx40-704x on 2-Way Valves and Setting up Actuator/Linkage/Valve Assembly.

- Apply power to the actuator and check the system's operation for heating or cooling output, in response to the control signal.
- Refer to the appropriate actuator General Instructions sheet for actuator wiring and application information. For valve body installation and application information, refer to the appropriate valve body General Instructions sheet. Refer to "Applicable Literature" on page 1.

#### B4. Mx40-704x Spring Return Actuators without Manual Override — 3-Way Valves

- a. Confirm that the NYBA-161 anti-rotation stud is installed in the wide slot of the linkage (refer to Figure-1 on page 3). Install the actuator onto the linkage and 3-way valve, and set up the assembly, according to Figure-6 below.

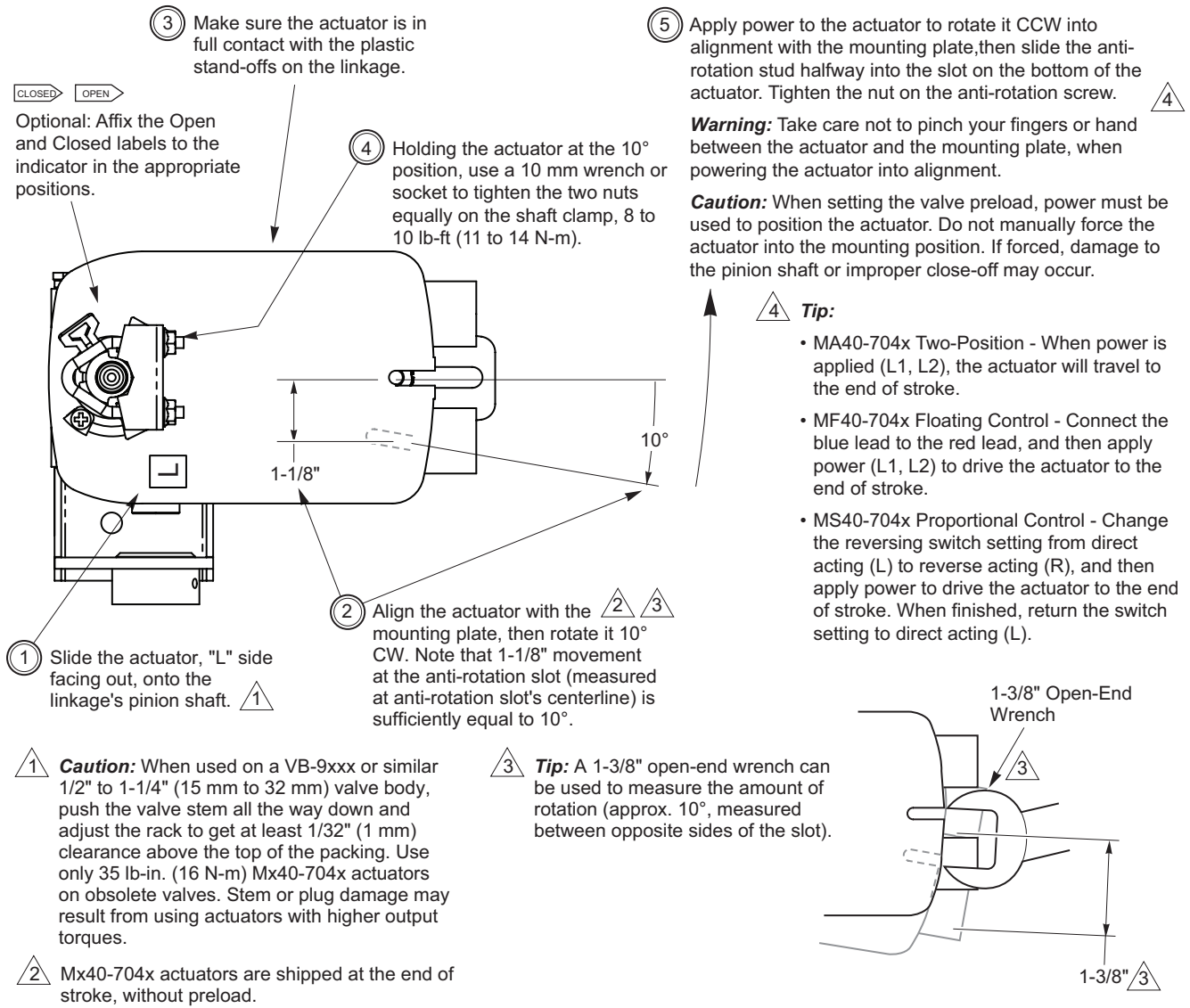

Figure-1 □ Mounting Mx40-704x on 3-Way Valves and Setting up Actuator/Linkage/Valve Assembly.

- b. Apply power to the actuator and check the system's operation for heating or cooling output, in response to the control signal.
- c. Refer to the appropriate actuator General Instructions sheet for actuator wiring and application information (see "Applicable Literature (contd)" on page 2). For valve body installation and application information, refer to the appropriate valve body General Instructions sheet.